

Dec.1.2021 Copyright 2021 HIROSE ELECTRIC CO., LTD. All Rights Reserved.
 In case of consideration for using Automotive equipment / device which demand high reliability, kindly contact our sales window correspondents.

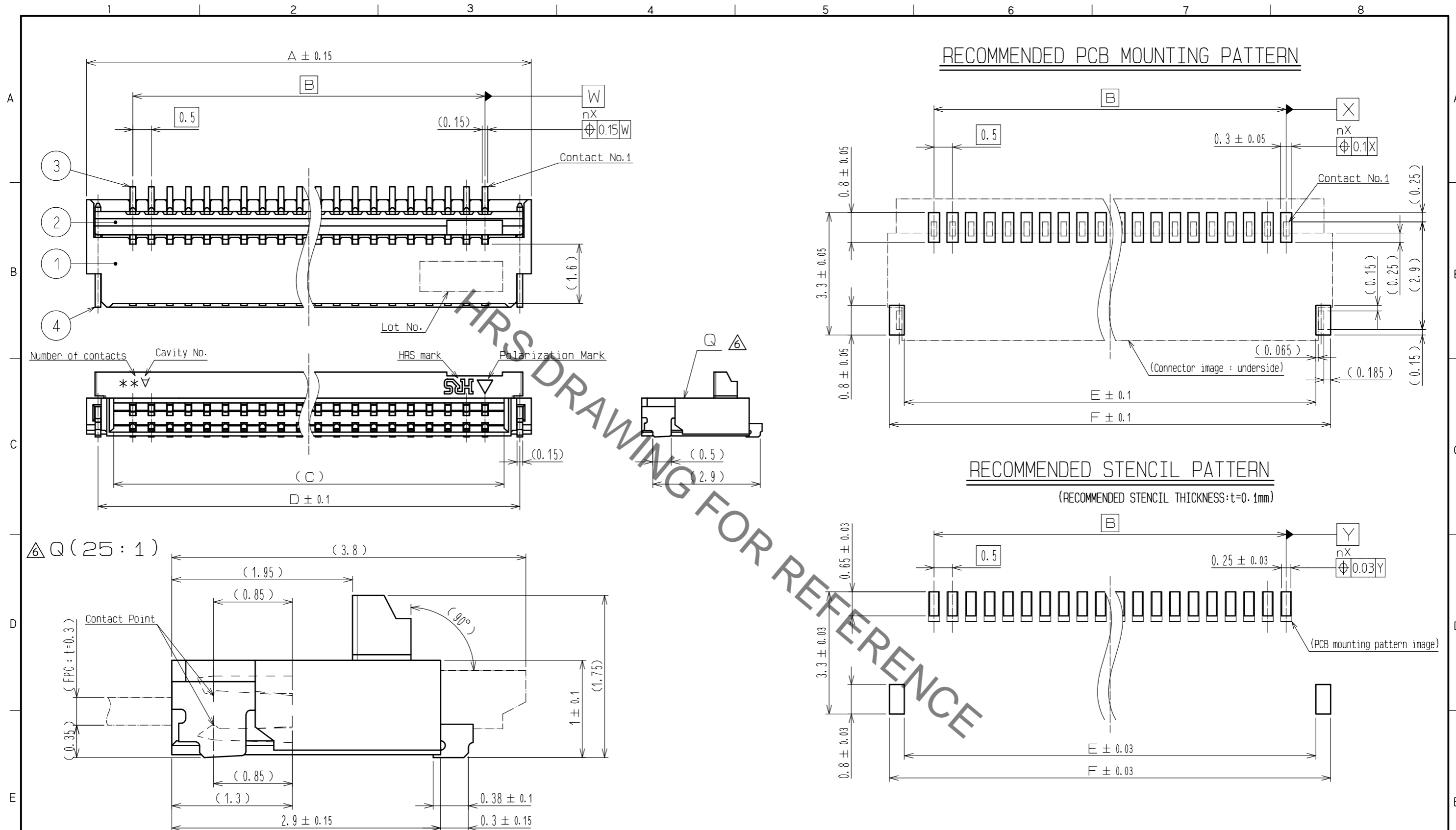

- NOTE
- The dimensions in parentheses are for reference.
 - Lead coplanarity including reinforced metal fittings shall be 0.1 MAX.
 - To be delivered with tape and reel packages. See attached packaging specifications for details.
 - Note that preventive hole for sink mark could be added for improvement.
 - The quality remains good, even with the dark spots, which could occasionally occur on molded plastic.
 - This product satisfies halogen free requirements defined as 900 ppm maximum chlorine, 900 ppm maximum bromine, and 1500 ppm maximum total of chlorine and bromine.
 - Material of the actuator for 8 pos. is LCP, and the material of other positions is Polyamide.
 - 'n' represents the number of contacts.

4	PHOSPHOR BRONZE (PLATED MATERIAL)	TIN PLATING (REFLOW FINISHED) 1 μ M MIN OVER COPPER 0.3 μ M MIN	8	(CONNECTOR)			
3	PHOSPHOR BRONZE	(CONTACT AREA LEAD) GOLD PLATING 0.05 μ M MIN OVER NICKEL 1 μ M MIN (OTHER) NICKEL PLATING 1 μ M MIN	7	POLYSTYRENE			
2	LCP/PA \triangleleft 7	BLACK UL94V-0	6	POLYESTER			
1	LCP	GRAY UL94V-0	5	POLYSTYRENE			
NO.	MATERIAL	FINISH . REMARKS	NO.	MATERIAL	FINISH . REMARKS		
UNITS mm	\odot \triangleleft	SCALE 10 : 1	COUNT 18	DESCRIPTION OF REVISIONS DIS-F-00010753	DESIGNED SE. YOKOYAMA	CHECKED HY. YAMAZAKI	DATE 20210908
APPROVED : MO. ISHIDA		20131129		DRAWING NO. EDC-159714-50-04			
CHECKED : HS. SAKAMOTO		20131129		PART NO. FH34SRJ-*S-0.5SH(50)			
DESIGNED : YS. EBI		20131128		CODE NO. CL580			
DRAWN : NM. SANPEI		20131128					

Dec.1.2021 Copyright 2021 HIROSE ELECTRIC CO., LTD. All Rights Reserved.
In case of consideration for using Automotive equipment / device which demand high reliability, kindly contact our sales window correspondents.

RECOMMENDED FPC PATTERN (20:1)

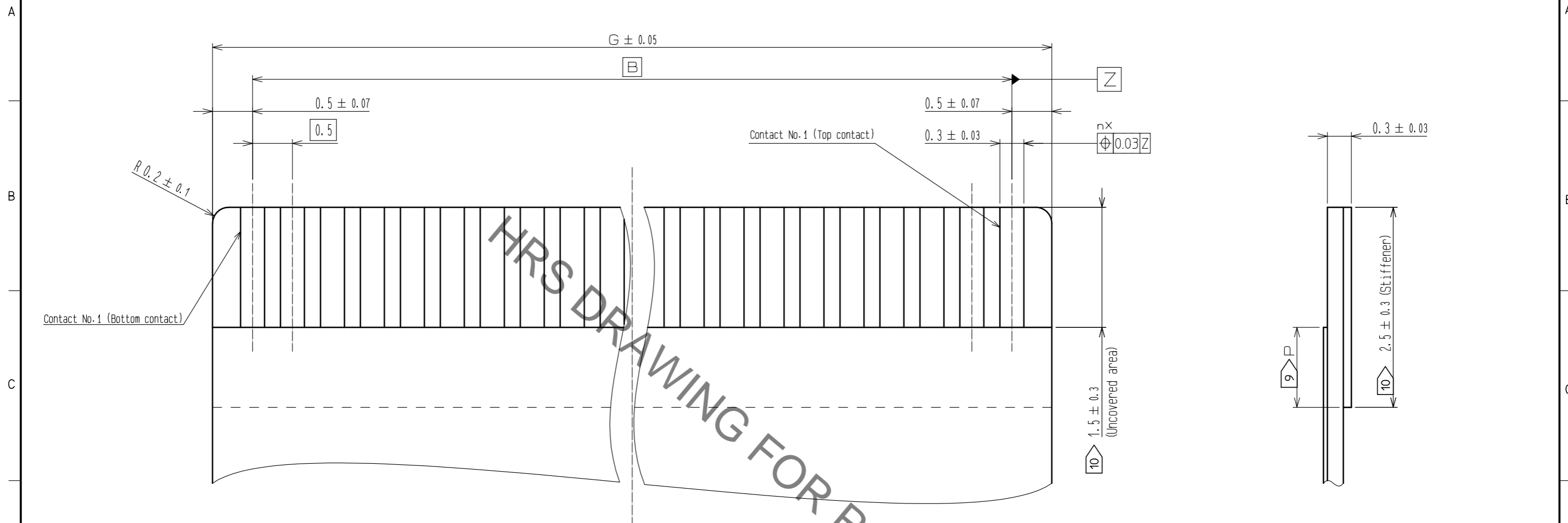

FPC CONFIGURATION (REFERENCE EXAMPLE) (FREE)

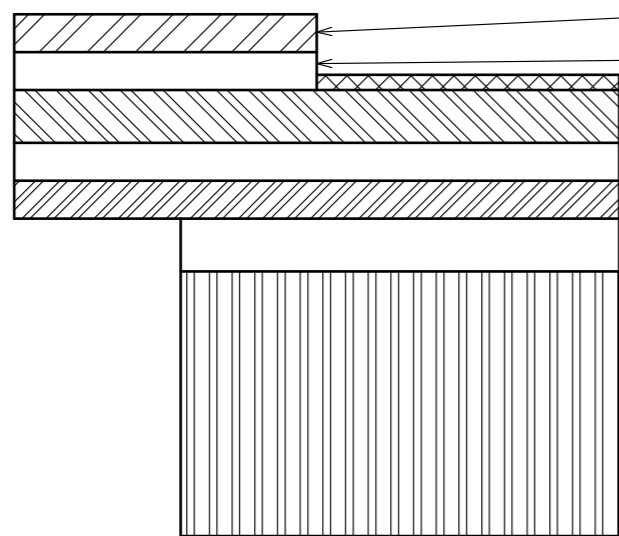

MATERIAL NAME	MATERIAL	THICKNESS(μm)
COVERING FILM LAYER	POLYIMIDE 1 mil	25
COVER ADHESIVE		25
SURFACE TREATMENT	1μm TO 5μm NICKEL UNDERPLATED 0.2μm GOLD PLATED.	(3)
COPPER FOIL	Cu 1 OZ	35
BASE ADHESIVE	HEAT-HARDENED ADHESIVE	25
BASE FILM	POLYIMIDE 1 mil	25
REINFORCEMENT MATERIAL ADHESIVE	HEAT-HARDENED ADHESIVE	35
STIFFENER	POLYIMIDE 7 mil	175

- NOTE
- 9 Dimension P must be 0.5mmMIN.
 - 10 For the compatibility with FH19SC series connectors(bottom contact). Change the length of uncoverd area to be 2.5mm +/-0.3 . And the stiffener length to be 3.5mm +/-0.3. (The pin numbers will not be compatible)
 - 11 Recommended puncher direction:
From conductor side to stiffener side.

<RECOMMENDED FPC>

HRS	DRAWING NO.	EDC-159714-50-04
	PART NO.	FH34SRJ-*S-0.5SH(50)
	CODE NO.	CL580

6/29

Dec.1.2021 Copyright 2021 HIROSE ELECTRIC CO., LTD. All Rights Reserved.
 In case of consideration for using Automotive equipment / device which demand high reliability, kindly contact our sales window correspondents.

EMBOSSED CARRIER TAPE DIMENSION (2:1)

REEL DIMENSION (FREE)

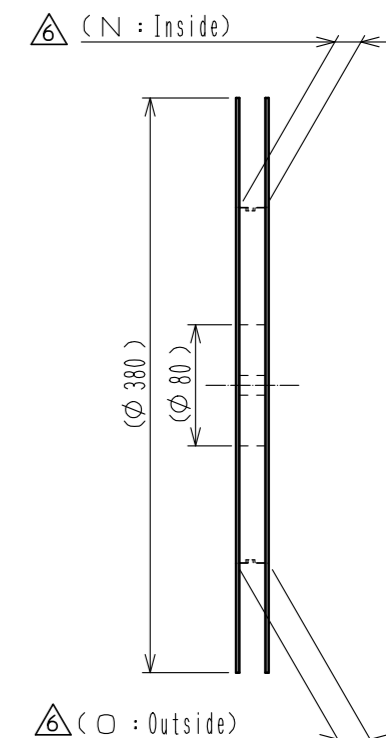
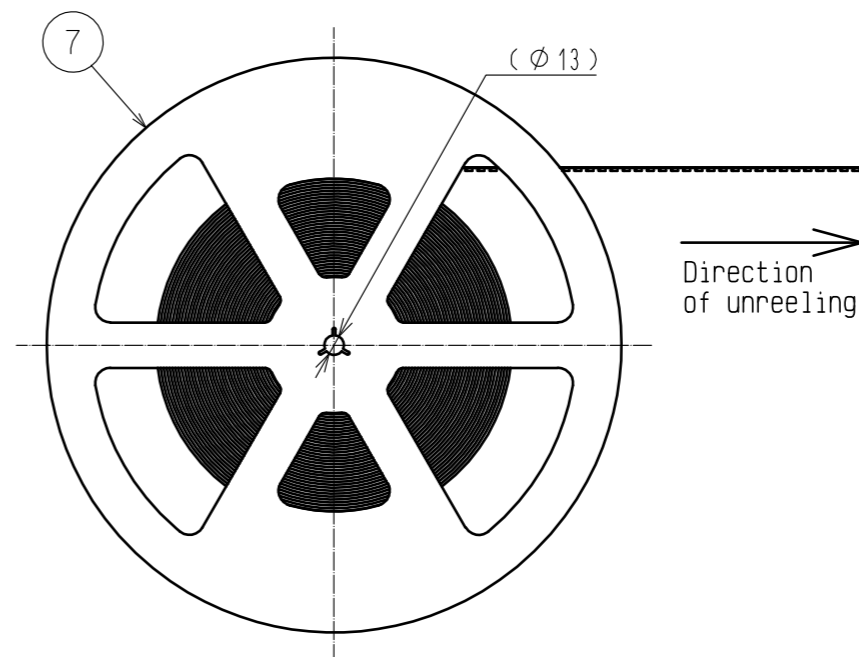
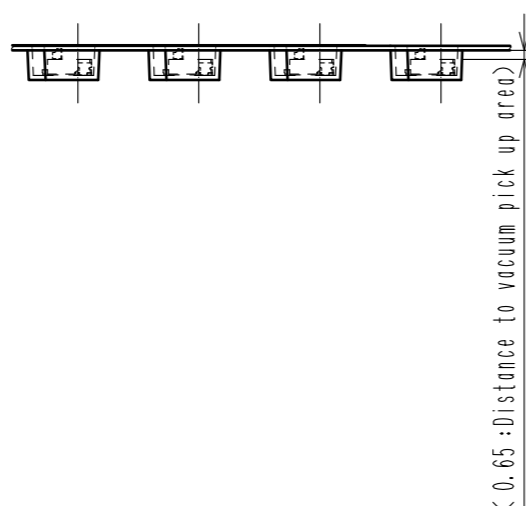
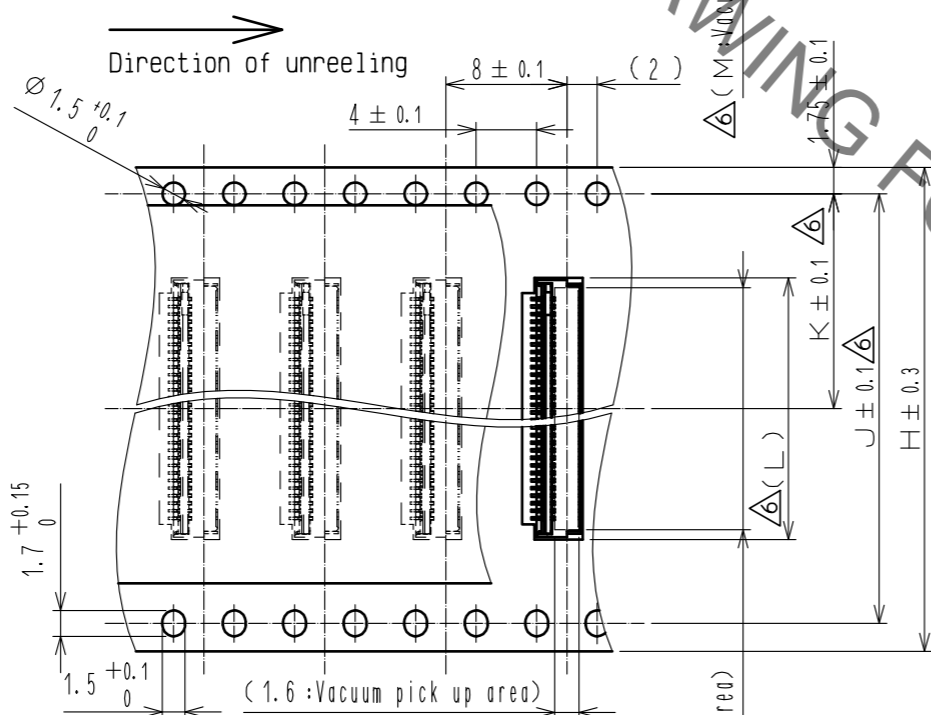
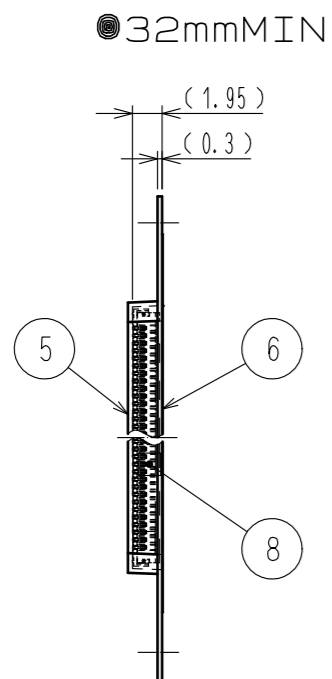
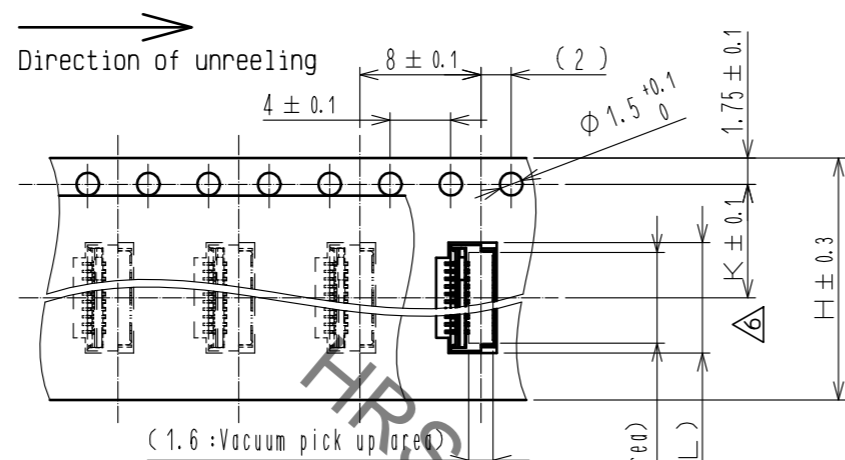
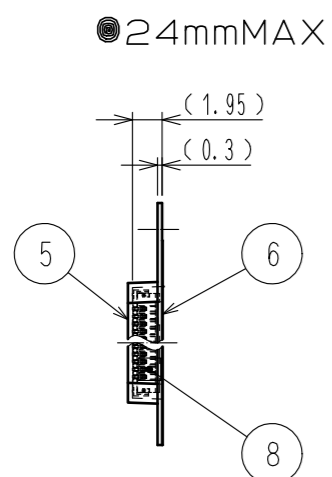

LEADER, TRAILER DIMENSION (FREE)

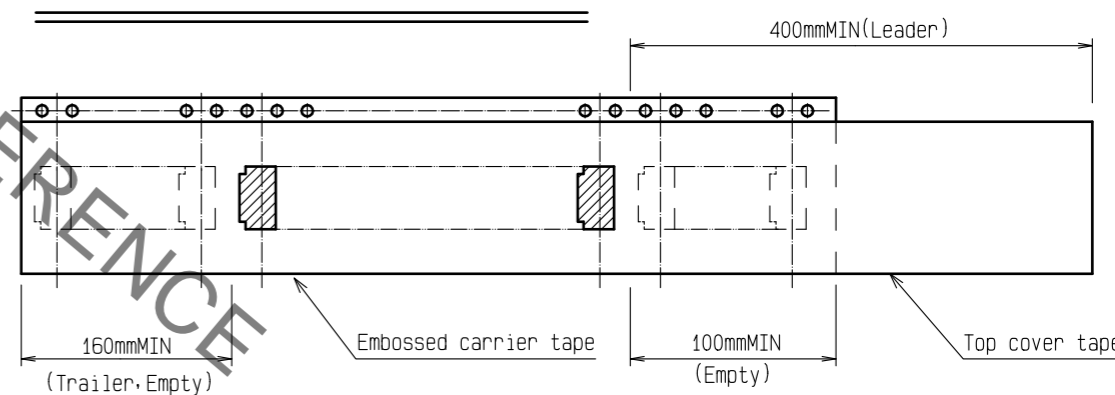

NOTE 12 Per reel : 5000 connectors.
 13 Refer to JIS C 0806 and IEC 60286-3
 (Packaging of components for automatic handling.)

<DRAWING FOR PACKING>

HRS	DRAWING NO.	EDC-159714-50-04
	PART NO.	FH34SRJ-*S-0.5SH(50)
	CODE NO.	CL580

6/3/9

Dec.1.2021 Copyright 2021 HIROSE ELECTRIC CO., LTD. All Rights Reserved.
In case of consideration for using Automotive equipment / device which demand high reliability, kindly contact our sales window correspondents.

PART NUMBER	CODE NUMBER	NUMBER OF CONTACTS	DIMENSION OF CONNECTOR, FPC,PCB MOUNTING PATTERN AND STENCIL							DIMENSION OF DRAWING FOR PACKING						
			A	B	C	D	E	F	G	H	J	K	L	M	N	O
FH34SRJ-4S-0.5SH(50)	CL580-1238-7-50	4	4	1.5	2.53	3.38	3.1	3.9	2.5	16	—	7.5	4.3	3	17.4	21.4
FH34SRJ-5S-0.5SH(50)	CL580-1264-7-50	5	4.5	2	3.03	3.88	3.6	4.4	3	16	—	7.5	4.7	3.5	17.4	21.4
FH34SRJ-6S-0.5SH(50)	CL580-1236-1-50	6	5	2.5	3.53	4.38	4.1	4.9	3.5	16	—	7.5	5.3	4	17.4	21.4
FH34SRJ-7S-0.5SH(50)	CL580-1200-0-50	7	5.5	3	4.03	4.88	4.6	5.4	4	16	—	7.5	5.8	4.5	17.4	21.4
FH34SRJ-8S-0.5SH(50)	CL580-1231-8-50	8	6	3.5	4.53	5.38	5.1	5.9	4.5	16	—	7.5	6.3	5	17.4	21.4
FH34SRJ-9S-0.5SH(50)	CL580-1262-1-50	9	6.5	4	5.03	5.88	5.6	6.4	5	16	—	7.5	6.7	5.5	17.4	21.4
FH34SRJ-10S-0.5SH(50)	CL580-1251-5-50	10	7	4.5	5.53	6.38	6.1	6.9	5.5	16	—	7.5	7.3	6	17.4	21.4
FH34SRJ-11S-0.5SH(50)	CL580-1258-4-50	11	7.5	5	6.03	6.88	6.6	7.4	6	16	—	7.5	7.8	6.5	17.4	21.4
FH34SRJ-12S-0.5SH(50)	CL580-1253-0-50	12	8	5.5	6.53	7.38	7.1	7.9	6.5	24	—	11.5	8.3	7	25.4	29.4
FH34SRJ-14S-0.5SH(50)	CL580-1252-8-50	14	9	6.5	7.53	8.38	8.1	8.9	7.5	24	—	11.5	9.3	8	25.4	29.4
FH34SRJ-16S-0.5SH(50)	CL580-1259-7-50	16	10	7.5	8.53	9.38	9.1	9.9	8.5	24	—	11.5	10.3	9	25.4	29.4
FH34SRJ-18S-0.5SH(50)	CL580-1248-0-50	18	11	8.5	9.53	10.38	10.1	10.9	9.5	24	—	11.5	11.3	10	25.4	29.4
FH34SRJ-20S-0.5SH(50)	CL580-1256-9-50	20	12	9.5	10.53	11.38	11.1	11.9	10.5	24	—	11.5	12.3	11	25.4	29.4
FH34SRJ-22S-0.5SH(50)	CL580-1254-3-50	22	13	10.5	11.53	12.38	12.1	12.9	11.5	24	—	11.5	13.3	12	25.4	29.4
FH34SRJ-24S-0.5SH(50)	CL580-1255-6-50	24	14	11.5	12.53	13.38	13.1	13.9	12.5	24	—	11.5	14.3	13	25.4	29.4
FH34SRJ-26S-0.5SH(50)	CL580-1247-8-50	26	15	12.5	13.53	14.38	14.1	14.9	13.5	24	—	11.5	15.3	14	25.4	29.4
FH34SRJ-30S-0.5SH(50)	CL580-1232-0-50	30	17	14.5	15.53	16.38	16.1	16.9	15.5	32	28.4	14.2	17.3	16	33.4	37.4
FH34SRJ-32S-0.5SH(50)	CL580-1257-1-50	32	18	15.5	16.53	17.38	17.1	17.9	16.5	32	28.4	14.2	18.3	17	33.4	37.4
FH34SRJ-34S-0.5SH(50)	CL580-1261-9-50	34	19	16.5	17.53	18.38	18.1	18.9	17.5	32	28.4	14.2	19.3	18	33.4	37.4
FH34SRJ-40S-0.5SH(50)	CL580-1260-6-50	40	22	19.5	20.53	21.38	21.1	21.9	20.5	44	40.4	20.2	22.3	21	45.4	49.4
FH34SRJ-45S-0.5SH(50)	CL580-1265-0-50	45	24.5	22	23.03	23.88	23.6	24.4	23	44	40.4	20.2	24.7	23.5	45.4	49.4
FH34SRJ-50S-0.5SH(50)	CL580-1266-2-50	50	27	24.5	25.53	26.38	26.1	26.9	25.5	44	40.4	20.2	27.2	26	45.4	49.4

< DIMENSION TABLE >

HRS	DRAWING NO.	EDC-159714-50-04
	PART NO.	FH34SRJ-*S-0.5SH(50)
	CODE NO.	CL580
		△ 4/9

Dec.1.2021 Copyright 2021 HIROSE ELECTRIC CO., LTD. All Rights Reserved.
In case of consideration for using Automotive equipment / device which demand high reliability, kindly contact our sales window correspondents.

This connector features small, thin and back flip design, requiring delicate and careful handling. To prevent connector/FPC breakage and contact failure (mating failure, FPC pattern breakage, etc), read through the instructions shown below and handle the connector properly. Each values indicating here are for reference and may differ from standard value.

[Operation and Precautions]

1. Initial condition

Actuator does not have to be operated before inserting FPC, as the connector is delivered with the actuator opened.

[Caution]

- Do not close the actuator before inserting FPC.
- Closing the actuator without FPC could make the contact gap smaller, which could increase the FPC insertion force.
- Do not insert FPC or operate actuator before mounting.

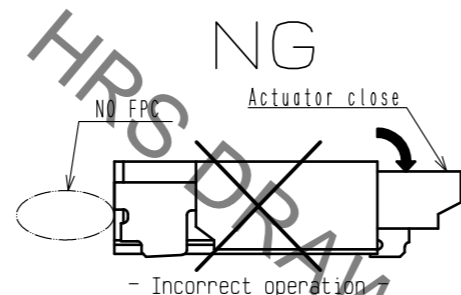
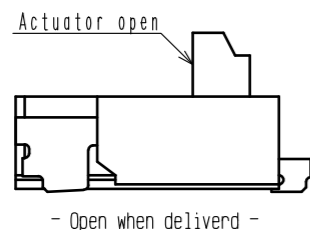

2. How to insert FPC

Insert the FPC into the connector opening horizontally to the PCB plane. Insert it properly to the very end.

[Caution]

- Insert the FPC with the actuator opened.
- Do not twist the FPC to up and down, right and left or an angle.

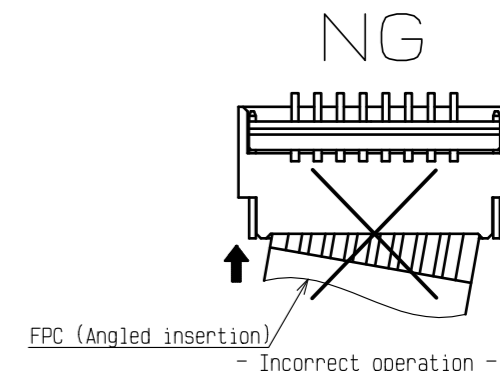
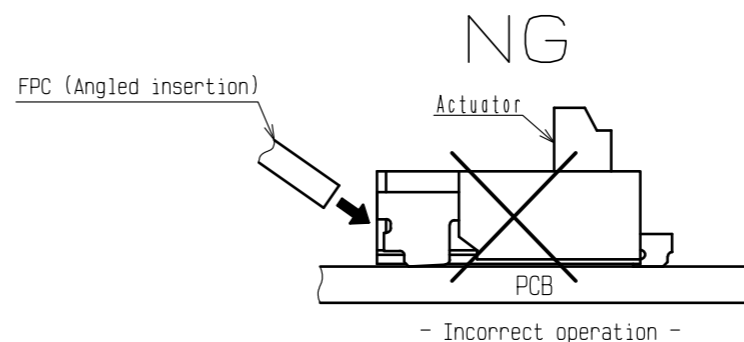
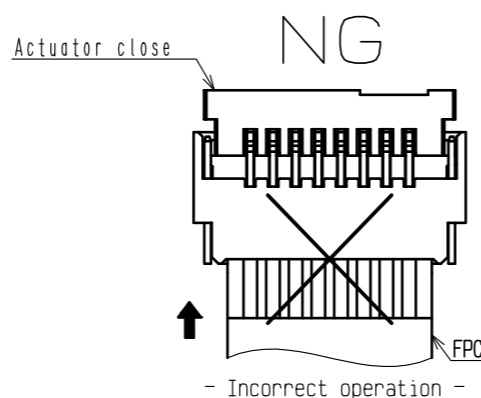
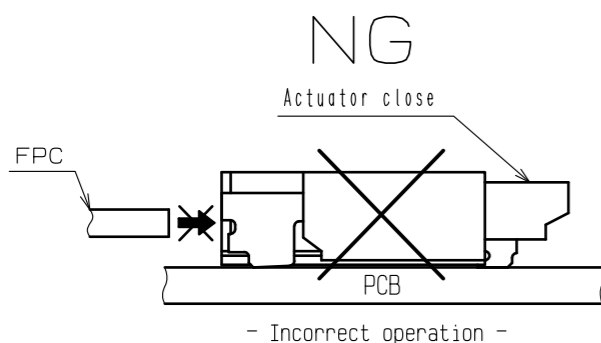
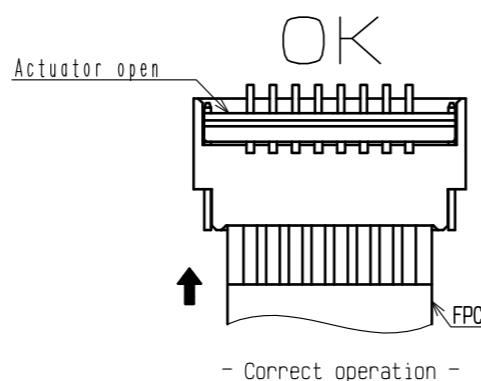
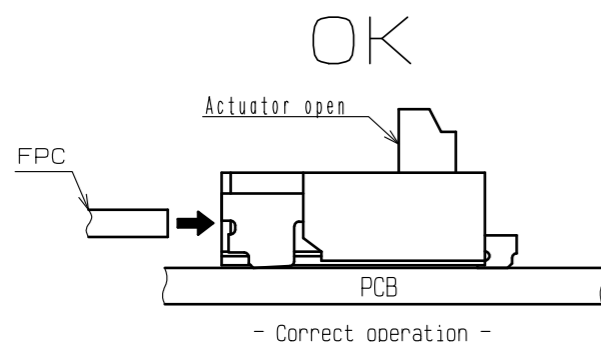

3. FPC insertion check (for using contacts on the top, for FPC pattern only applicable to FH34S*)

Incorrect operation modes are prevented by visual check, comparing positions of housing opening end line and FPC pattern line.

[Caution]

- Do not insert the FPC at an angle and/or stop it before insertion is completed.

OK

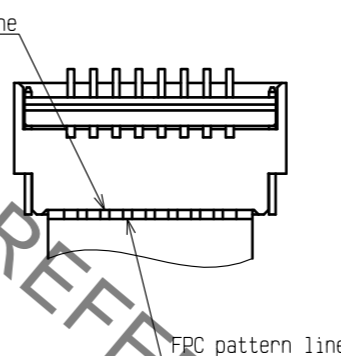

NG

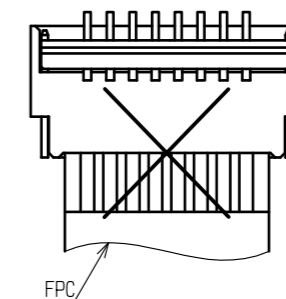

NG

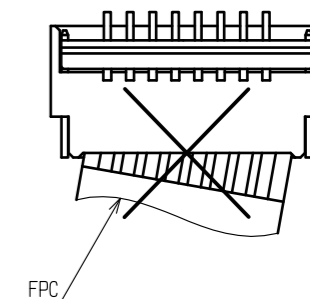

<INSTRUCTION MANUAL(1)>

HRS

DRAWING NO.	EDC-159714-50-04
PART NO.	FH34SRJ-*S-0.5SH(50)
CODE NO.	CL580

5/9

Dec.1.2021 Copyright 2021 HIROSE ELECTRIC CO., LTD. All Rights Reserved.
In case of consideration for using Automotive equipment / device which demand high reliability, kindly contact our sales window correspondents.

4. How to lock

Apply load to rotate the actuator by 90 degree after inserting the FPC.

[Caution]

- The actuator rotates around the rotational axis as shown below.
- Do not try to rotate the actuator further towards the opening direction or apply any extra force to the actuator while it is fully open.
- Do not pinch or pick the actuator to lift.
- Operate the actuator by hand without using sharp tool such as Tweezers.
- To close the actuator, operate at the center of the actuator.
- To close the actuator, do not operate the actuator at one end only.
- Do not apply excess force to the housing during the operation.

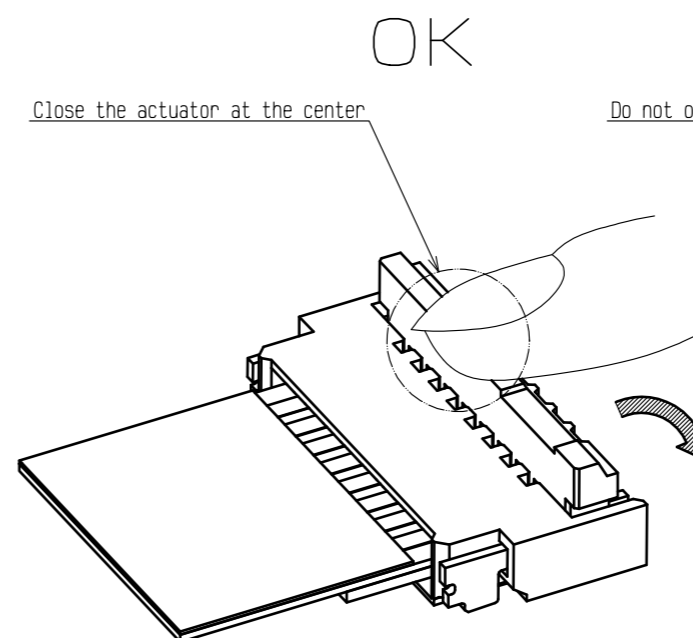
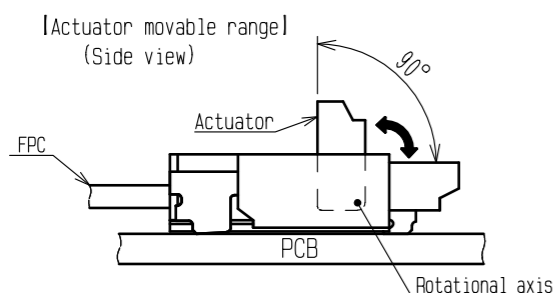

- Correct operation -

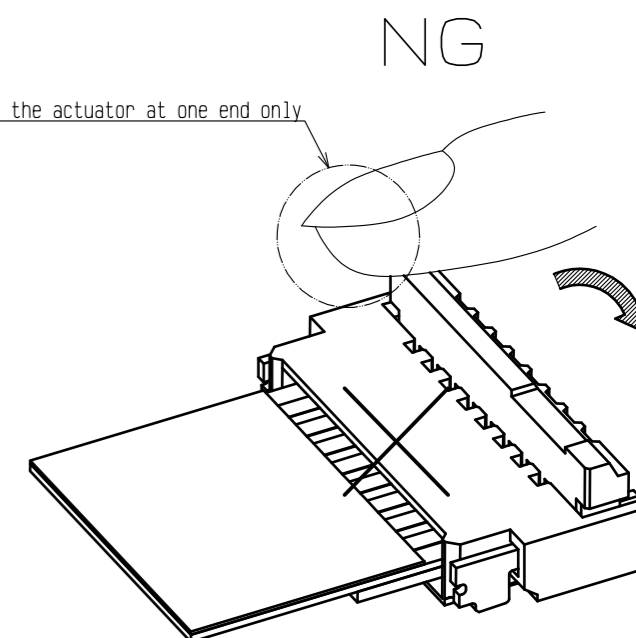

- Incorrect operation -

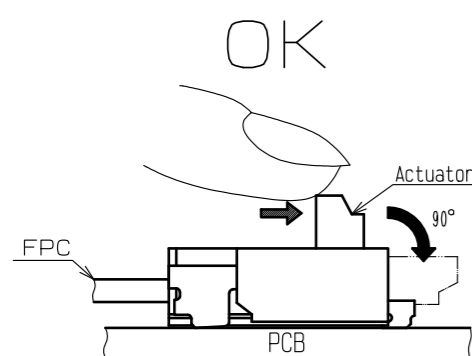

- Correct operation -

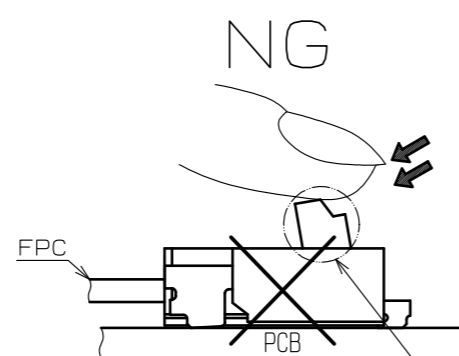

- Incorrect operation -

Actuator receives inappropriate force in reverse direction.

Do not apply excess force to the housing during the operation.

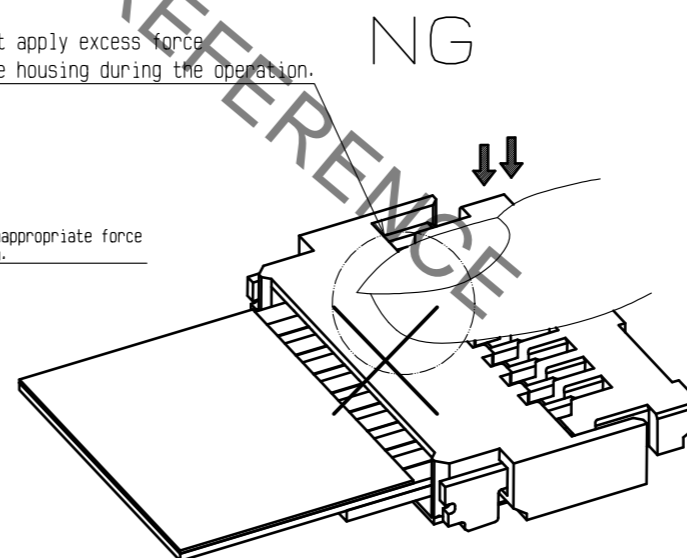

- Incorrect operation -

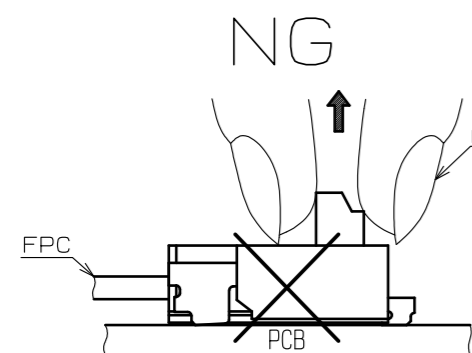

- Incorrect operation -

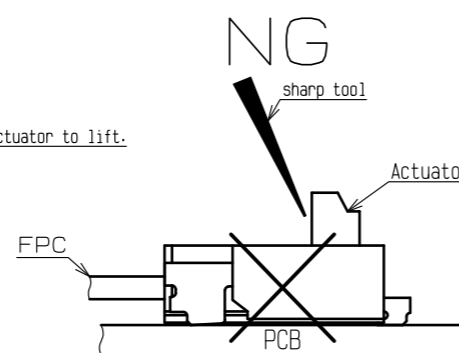

- Incorrect operation -

<INSTRUCTION MANUAL (2)>

HRS

DRAWING NO.	EDC-159714-50-04
PART NO.	FH34SRJ-*S-0.5SH(50)
CODE NO.	CL580

6/9

Dec.1.2021 Copyright 2021 HIROSE ELECTRIC CO., LTD. All Rights Reserved.
In case of consideration for using Automotive equipment / device which demand high reliability, kindly contact our sales window correspondents.

5. How to unlock

Slowly flip up the actuator to release the lock.

[Caution]

- The actuator rotates 90 degrees max.
- Do not try to rotate the actuator further towards the opening direction or apply any extra force to the actuator while it is fully open.
- Open the actuator right above.
- Do not attempt to open further or to open it by applying horizontal force as this may cause its damage.
- Please note that the connector is back flip style connector, and the opening for FPC insertion and the actuator face the opposite direction. Do not try to lift the actuator at the FPC insertion opening side.
- Operate the actuator by hand without using sharp tool such as Tweezers.
- To open the actuator, operate at the center of the actuator.
- To open the actuator, do not operate the actuator at one end only.

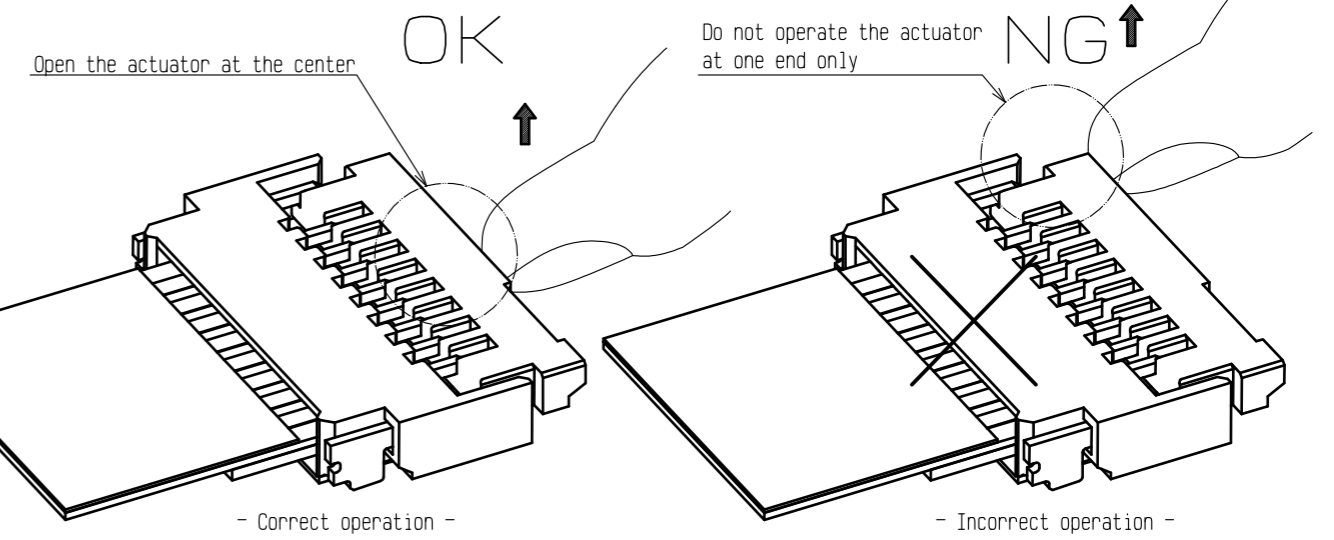

6. How to remove FPC

After rotating the actuator to the fully opened position carefully withdraw the FPC in the direction parallel to the PCB mounting surface.

[Caution]

- Do not withdraw the FPC at inclined towards vertical and horizontal angle.
- Do not attempt to pull the FPC without unlocking the actuator.

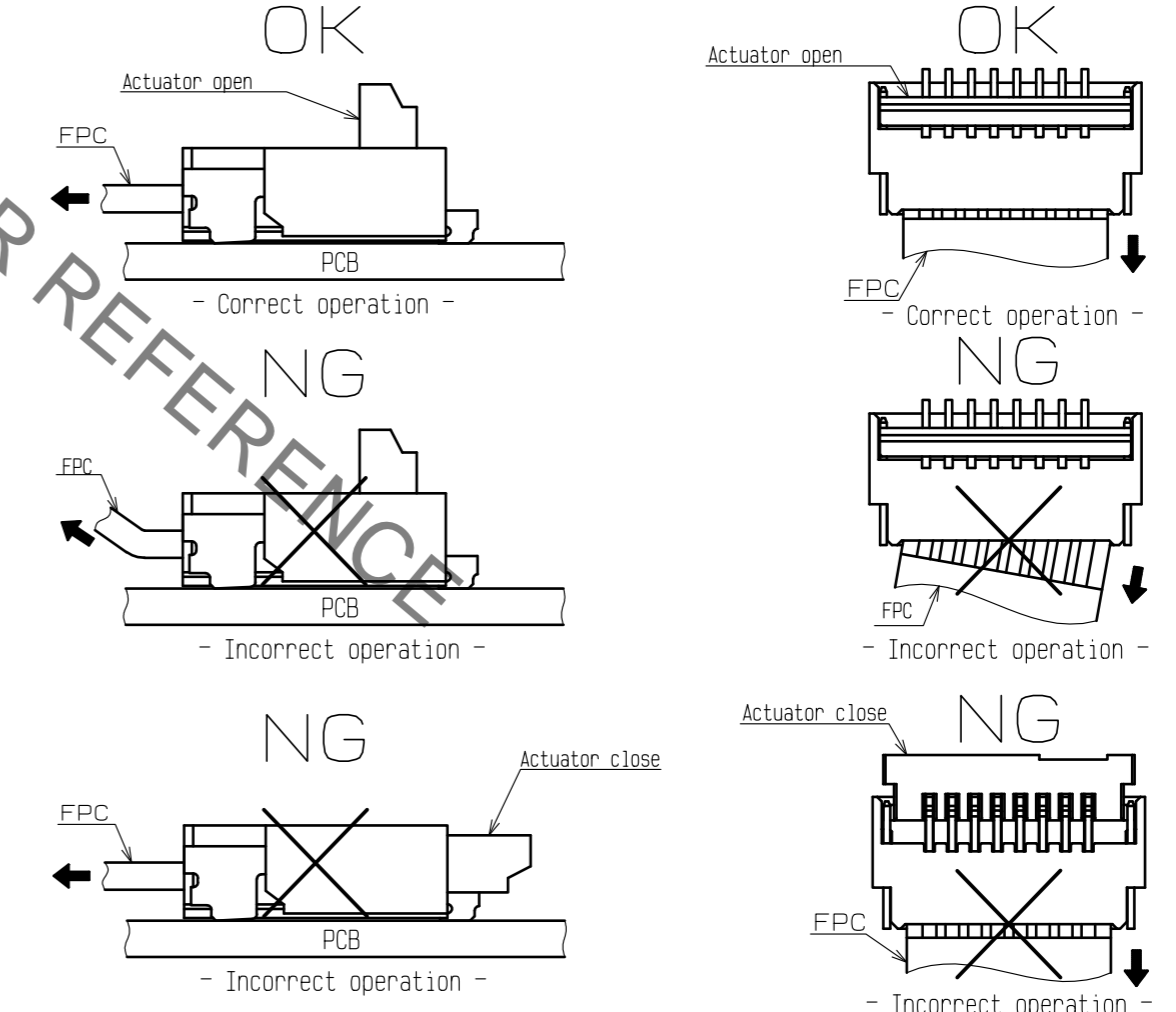
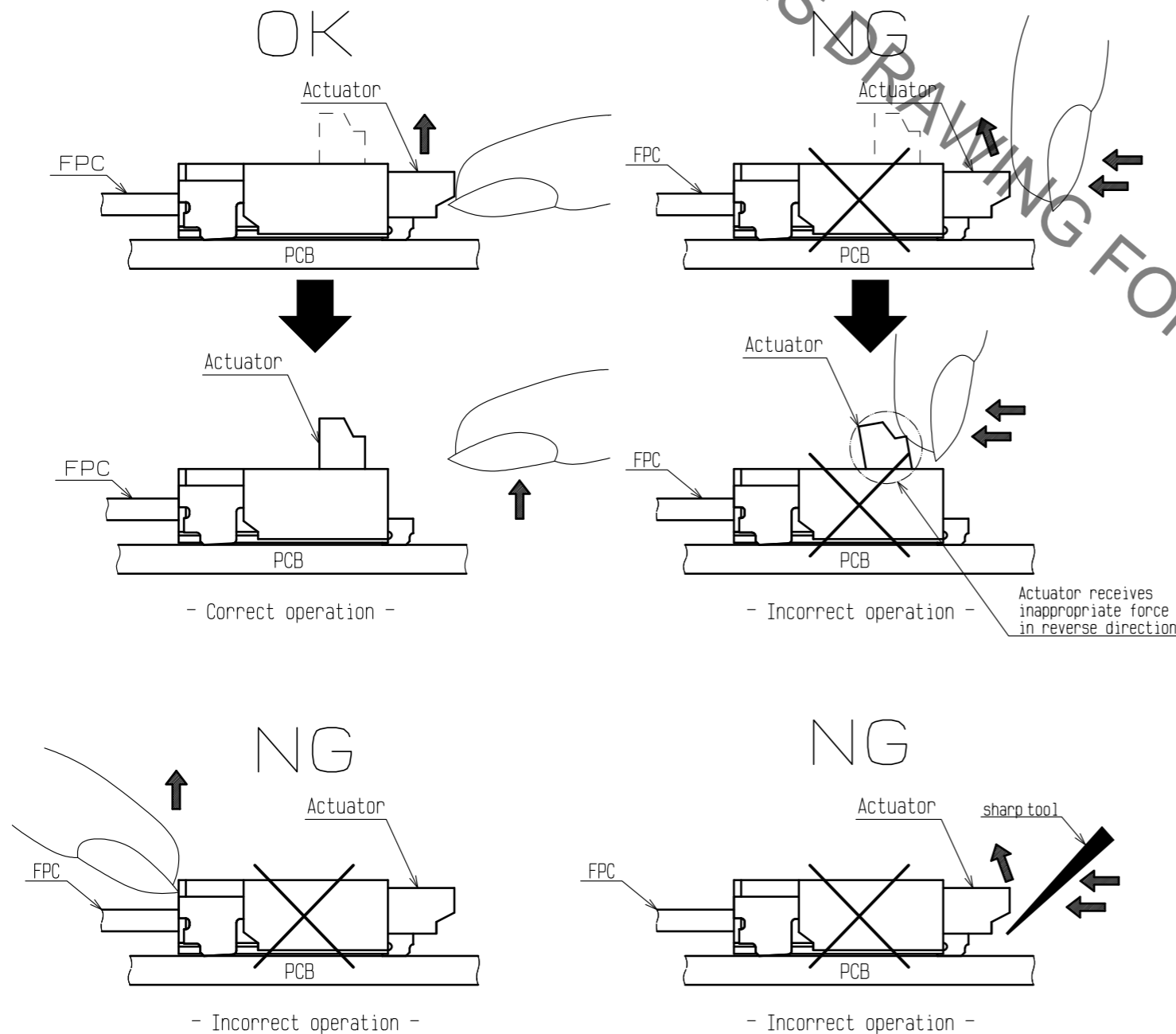

<INSTRUCTION MANUAL (3)>

HRS	DRAWING NO.	EDC-159714-50-04
	PART NO.	FH34SRJ-*S-0.5SH(50)
	CODE NO.	CL580
		6/7

Dec.1.2021 Copyright 2021 HIROSE ELECTRIC CO., LTD. All Rights Reserved.
In case of consideration for using Automotive equipment / device which demand high reliability, kindly contact our sales window correspondents.

[Precautions for component layout]

While the FPC is under tension due to the connecting configuration, extra stress may be applied to the connector. As a result, conduction failure may occur due to the extra stress. In order to prevent such kind of conduction failure, please read through the following parts before making circuits/mechanism design.

[Caution]

- Avoid applying forces to/pulling the FPC along/perpendicular to the direction of FPC insertion. Avoid pushing/pulling the FPC upwards/downwards.
- If the FPC has to be curled/bended in your cabling design, please keep enough degree of freedom in your design to keep the FPC tension free. In this regard, the stiffener should be parallel to the PCB.
- If the FPC has to be curled/bended in your cabling design, do not curl/bend the FPC area near the connector. This may lead to conduction failure or FPC breakage. It is recommended to keep the FPC fixed to avoid applying stress through the FPC to the connector.
- Do not mount other components underneath the FPC stiffener which may interfere with the connection.
- Follow the recommended FPC design. Please consult with the FPC manufacturer about FPC bending performance and wire breakage strength while making design.
- Keep sufficient operating space for FPC insertion during layout design in order to avoid incorrect FPC insertion. Please keep enough FPC length and component layout space for assembly during design process. FPC with too short length may make the assembly difficult.
- Keep enough space for the rotation of the actuator during PCB and component layout design.
- ⚠ Please consult with our sales representative if you are using FPC with different configuration from our recommendation.

[Instructions for mounting on the PCB]

Follow the instructions shown below when mounting on the PCB.

[Caution]

- Refer to recommended layouts on page 1 for PCB and stencil pattern.
- Using either narrower land pattern or wider stencil pattern than recommendation may end up with excessive amount of solder/flux climbing on contact. Please inspect the size of solder fillet and flux climbing height of the mounted connector while using different land/stencil pattern from our recommendation.
- ⚠ Clearance between the mounting surface of the connector contact lead and the bottom of the housing is (0.03). Solder resist/silk screening applied underneath the connector may interfere with the connector. This may lead to soldering defect/insufficient fillet formation. Please verify your solder resist/silk screening design carefully before implementing the design.
- Please try to minimize the warpage of the PCB. Soldering failure could still occur due to the PCB warpage even if the coplanarity of the connector is under 0.1mm.
- If the connector is mounting on FPC, please make sure to put a stiffener on the backside of the FPC. Recommended stiffener: Glass epoxy material with thickness of 0.3 mm MIN.
- Do not apply 0.5 N or greater external force on the connector when unreeling or handling the connector before mounting. Excessive mechanical stress may damage the connector before mounting.
- Apply reflow temperature profile within the specified conditions. For specific applications, the recommended temperature may vary depending on type/ volume/thickness of solder paste and size/thickness of PCB. Please consult with your solder paste and equipment manufacturer for specific recommendations. The temperatures mentioned below refer to the PCB surface temperature near the connector contact leads.
- Reflow method: IR reflow
- Number of reflow cycles: 2 cycles MAX.

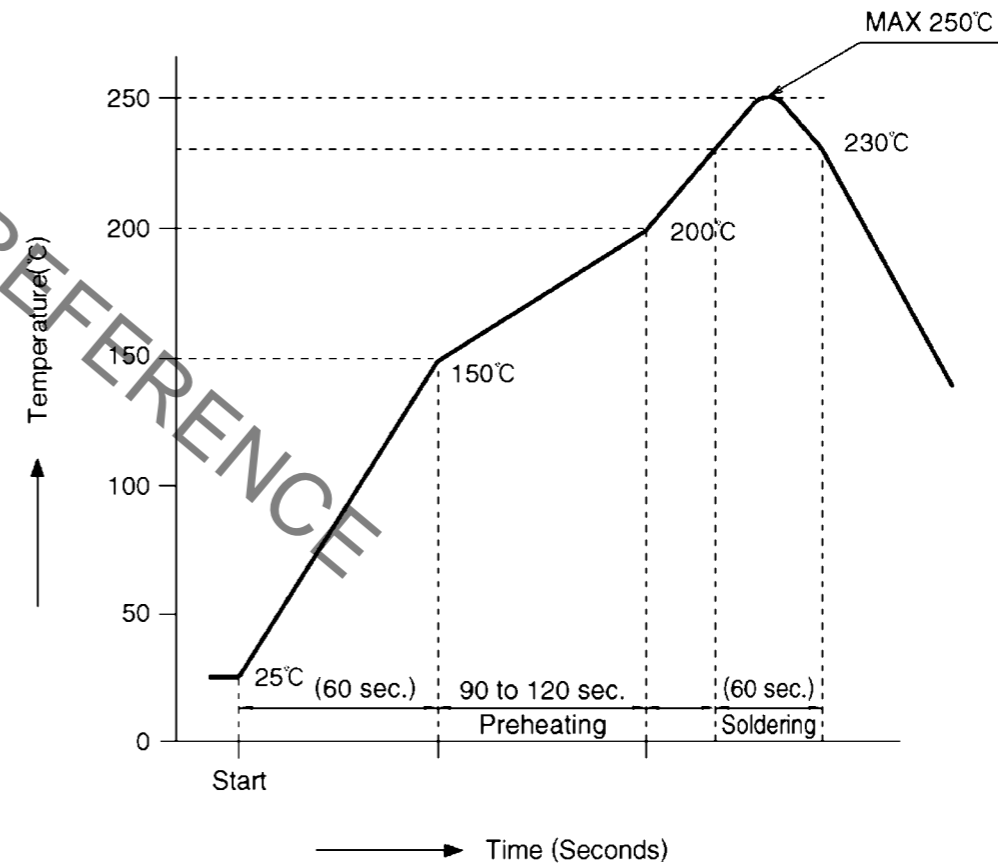
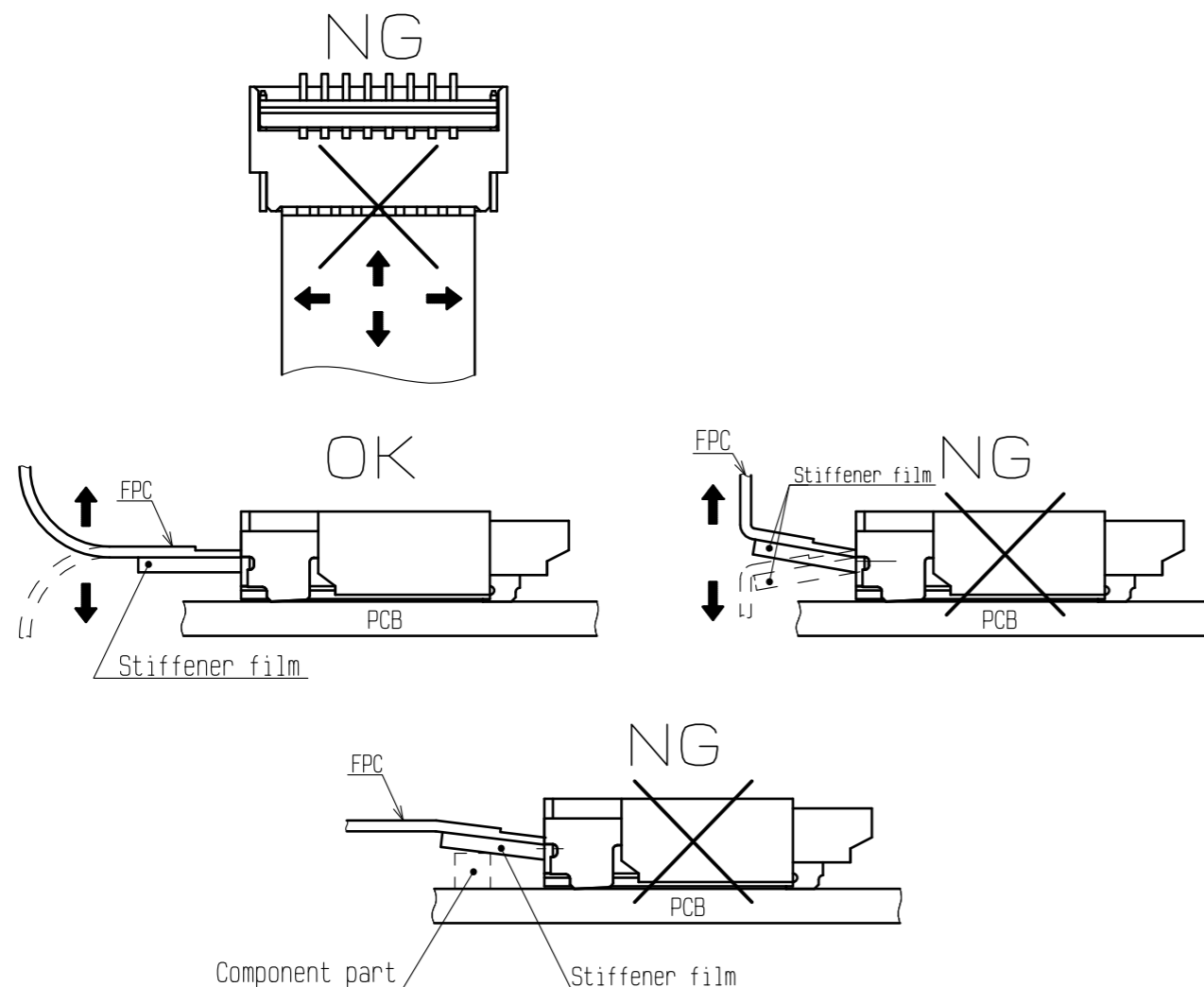

<INSTRUCTION MANUAL (4)>

HRS	DRAWING NO.	EDC-159714-50-04
	PART NO.	FH34SRJ-*S-0.5SH(50)
	CODE NO.	CL580
		⚠ 8/9

Dec.1.2021 Copyright 2021 HIROSE ELECTRIC CO., LTD. All Rights Reserved.
In case of consideration for using Automotive equipment / device which demand high reliability, kindly contact our sales window correspondents.

[Instructions for PCB handling after mounting the connector]

Follow the instructions shown below when mounting on the PCB.

[Caution]

- Splitting a large PCB into several pieces
 - Installing mounting screw on PCB
- During the assembly processes described above, care shall be taken so as not to give any stresses of deflection or twisting to the PCB. Stresses applied on PCB may damage the connector as well.
- The warpage of a 100 mm wide PCB should remain within 0.5 mm.
- The warpage of PCB may apply excessive stress on the connector and damage the connector.

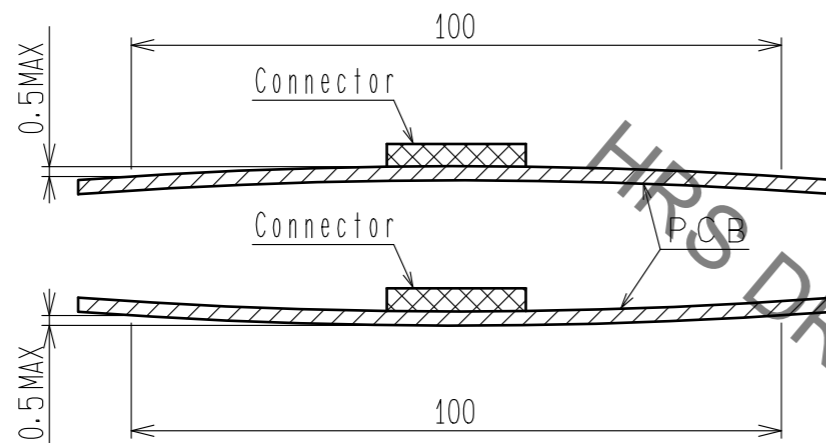

[Instructions on manual soldering]

Follow the instructions shown below when soldering the connector manually during repair work, etc.

[Caution]

- Do not perform manual soldering with the FPC inserted into the connector.
 - Do not heat the connector excessively. Be very careful not to let the soldering iron contact any parts other than connector leads. Otherwise, the connector may be deformed or melt.
 - Do not supply excessive solder (or flux).
- If excessive solder (or flux) is supplied on the contact lead, solder or flux may adhere to the contact point or rotating parts of the actuator, resulting in conduction failure or a rotation failure of the actuator. Supplying excessive solder to the metal fitting may hinder actuator rotation, resulting in breakage of the connector.

[Others]

- ⚠ Attachment of foreign particles with the connector contact may lead to conduction failure. In this particular case, the conduction failure may be fixed by re-inserting the FPC.
- ⚠ Please perform conduction check with caution. Conductivity probe may damage the connector contacts.

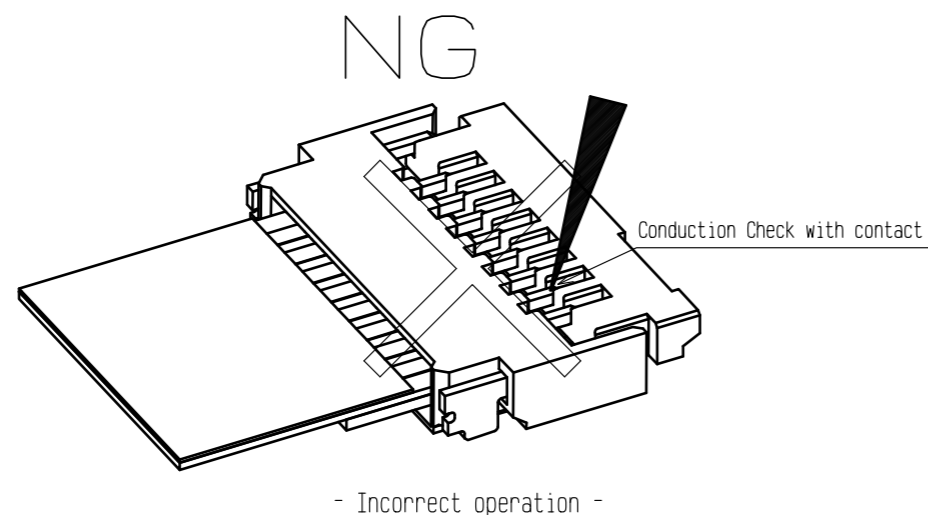

<INSTRUCTION MANUAL (5)>

HRS	DRAWING NO.	EDC-159714-50-04	
	PART NO.	FH34SRJ-*S-0.5SH<50>	
	CODE NO.	CL580	

Mouser Electronics

Authorized Distributor

Click to View Pricing, Inventory, Delivery & Lifecycle Information:

[Hirose Electric:](#)

[FH34SRJ-40S-0.5SH\(50\)](#)